

### Характеристики

<b>Свойства</b>	<p>Vacuum generator without control valves or system monitoring functions, with a high maximum vacuum value (85%)</p> <p>No moving parts, which means no wear and no maintenance</p> <p>Maximum suction capacity with minimum compressed air consumption</p> <p>Minimum size, low weight</p> <p>For decentralised vacuum generation in highly dynamic processes</p>
-----------------	---

<b>Применение</b>	<p>For universal use in lightweight gripper systems</p> <p>to handle air-tight workpieces as well as for automatic separation systems, e.g. in the plastics, electronics and packaging industries.</p> <p>Also ideal for the construction of ejector blocks for decentralised control of suction pads.</p>
-------------------	--

<b>Корпус</b>	Plastic (impact-resistant)
<b>Соединение</b>	Push-in coupling
<b>Глушитель</b>	Plastic
<b>Степень разрежения</b>	85 %
<b>Рабочее давление</b>	4.5 bar

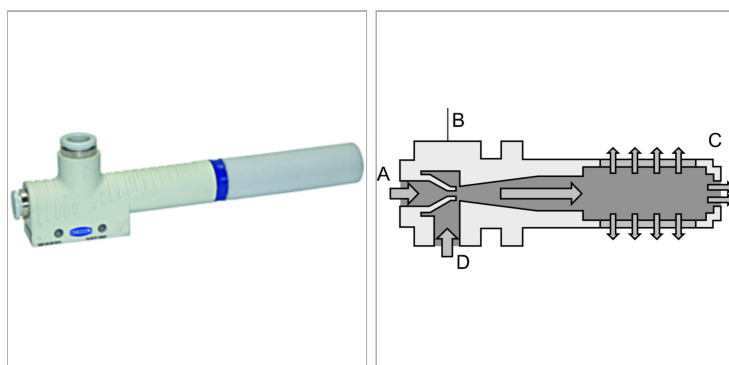

### Информация о продукте

<b>Размер форсунки</b>	1	<b>Расход воздуха при всасывании</b>	22 l/min
<b>Подключение системы сжатого воздуха</b>	4 mm	<b>макс. скорость откачки</b>	16 l/min
<b>Вакуумное соединение</b>	4 mm	<b>Размер</b>	71 mm x 10 mm x 28 mm

### Указания

Прочие данные только по запросу.

### Описание

Purely pneumatic vacuum ejector that operates on the Venturi principle. Compressed air enters the ejector at A and flows through the nozzle B. This results in a vacuum immediately behind the nozzle outlet, and air is drawn in through the vacuum inlet D. This air and the driving air leave the ejector via the silencer C.