

Характеристики

Входное давление	2 - 10 bar
Выходное давление	Max. 20 bar (regulated: max. 16 bar)
Область температур	-10 °C to +50 °C (40 mm bore), -10 °C to +60 °C (63 mm bore)
Рабочие среды	Filtered, unlubricated or lubricated compressed air. If lubrication is used, it must be continuous.
Уплотнение	Нитрильный каучук
Корпус	Aluminium, anodised
Труба	Anodised aluminium jacket
Дополнительная информация	Haltewinkel mit Mutter Druckregler mit Kunststoffgehäuse
Монтаж	Any position, with 4 mounting holes
P2:P1	1:1 to 1.6:1

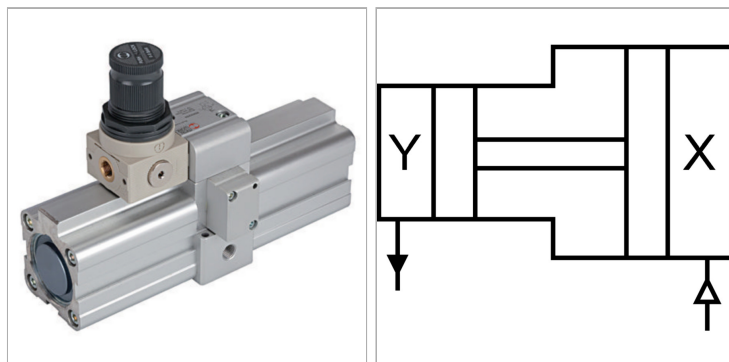

Информация о продукте

Соединение	G 3/8"	L	290 mm
Ø поршня	63 mm	H	183 mm

Указания

Прочие данные только по запросу. For information about calculating the filling times for different tank sizes, refer to the above-mentioned data sheet available on our website

Описание

Pressure multipliers (boosters) allow a separate compressed air store with up to double pressure to be installed for selected devices in a compressed air system without an external energy source, i.e. it is possible to work with a maximum pressure of 20 bar in a standard 10 bar system (maximum ratio 2:1). This is achieved using a double piston, which is operated by a combination of integrated check valves in such a way that the booster works automatically until the target pressure is reached in a compressed air tank and is then automatically switched off. A tank is always required to build up the pressure and store the compressed air!

Дополнительная информация

Fixing bracket with nut Pressure regulators with plastic body