

Характеристики

Исполнение	combinable with coupling HK AGN PBA
Материал	алюминий
Применение	for axial piston pumps HK PBA with flange 80x80

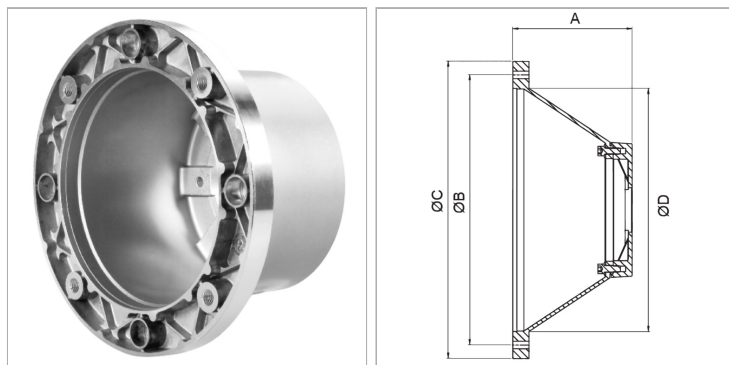

Информация о продукте

A	221 mm	Ø B	500 mm
Ø D	450 mm	Ø C	550 mm
Ø B	500 mm	Двигатель	BG 250 (55 kW)

Описание

Centring for motor and pump shaft