

Характеристики

Исполнение	combinable with coupling HK AGN PBA
Материал	алюминий
Применение	for axial piston pumps HK PBA with flange 80x80

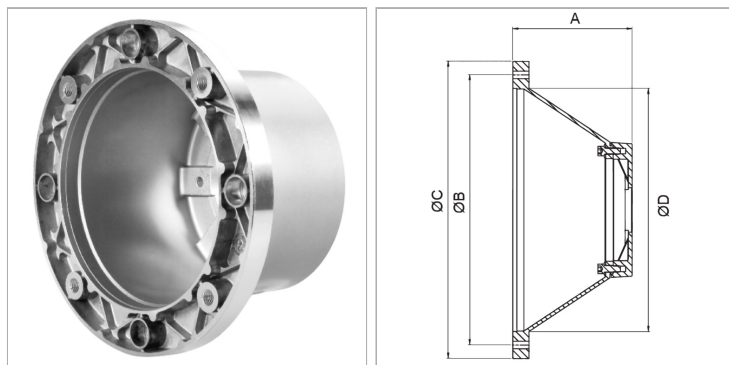

Информация о продукте

A	178 mm	Ø B	300 mm
Ø D	253 mm	Ø C	350 mm
Ø B	300 mm	Двигатель	BG 160/180 (11-22 kW)

Описание

Centring for motor and pump shaft